

# A molecular 1 : 2 demultiplexer

Ezequiel Perez-Inestrosa,\* Jose-María Montenegro, Daniel Collado and Rafael Suau

Received (in Cambridge, UK) 15th November 2007, Accepted 12th December 2007

First published as an Advance Article on the web 9th January 2008

DOI: 10.1039/b717690b

**A dual-channel fluorescent compound runs as a 1 : 2 digital demultiplexer (DEMUX) which can drive a single signal (proton) to two different destinations as a fluorescent photonic response; each fluorescent channel can be activated independently by careful selection of the excitation wavelength.**

Although the components of a molecular computer need not operate like microelectronic circuits, there have been several attempts at designing, synthesizing and characterizing chemical systems that mimic the operation of semiconductor logic gates.<sup>1–3</sup> On these grounds, implementing molecules with decision-making capabilities<sup>4</sup> is a strong motivation for seeking information-processing strategies based on molecules.<sup>5</sup>

Molecules, which can be interlocated between various reachable luminescent electronic states by using light, are optimum candidates for use as components of molecular based logic gates and there are several reports on molecular switches based on molecules and quantum dots showing dual fluorescence.<sup>6</sup> Using chemical systems to implement the most basic Boolean functions is now possible.<sup>7</sup> However, rather than relying on extensive physical connection of elementary gates, the construction of molecular logic networks can take advantage of functional integration within a single molecule, which can be accomplished *via* rational chemical design.

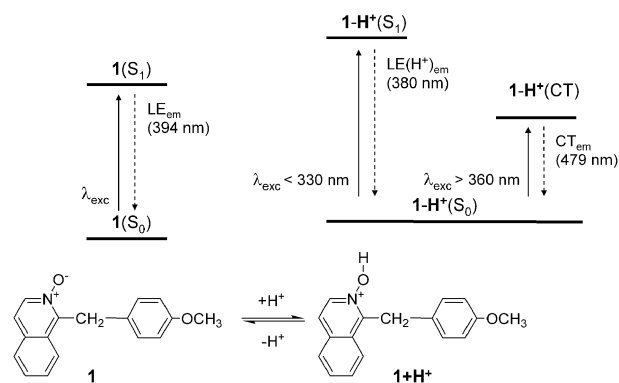
We have for some time studied how photoinduced electron transfer (PET) between covalently linked isoquinoline *N*-oxide as an electron acceptor and various electron donor systems might be used in order to perform binary and Boolean logic operations. The PET state accessible by this family of molecules exhibits dual-channel fluorescence emission (locally excited, LE, and charge transfer, CT, states) in an independent, nonannihilating mode. This peculiarity has allowed us to simultaneously integrate two independent operating channels in these molecules.<sup>8,9</sup>

Boolean algebra requires two types of electronic switches in order to control the flow of bit data, namely: multiplexers and demultiplexers. In digital signal processing, a multiplexer (MUX) takes several separate digital data streams and combines them into a single stream of a higher data rate. This allows multiple data streams to be carried from one place to another over a single physical link. A molecular 2 : 1 multiplexer has recently been reported.<sup>10</sup>

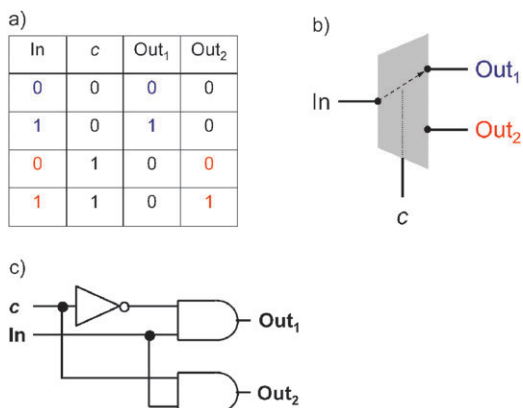
A complementary demultiplexer (DEMUX) is normally required at the receiving end of the data link. A DEMUX is a key subsystem of single flux circuits and systems in practical

applications that steers an input to one of many possible outputs. Recently, some authors have used combinations of organic molecules, lasers and third-harmonic generating crystals,<sup>11</sup> nanostructured systems based on plasmonic crystals<sup>12</sup> or nanocrystalline semiconductors<sup>13</sup> to construct chemical systems capable of operating as DEMUX. In this work, we developed a molecular 1 : 2 demultiplexer (**1**) comprising of two photochemically activated redox moieties covalently linked by a methylene branch (Fig. 1). As explained below, the molecule reacting to acids (protons) as the sole input can address the fluorescence response by switching the coding excitation wavelength in order to report the binary state of the input.

Fig. 2a shows the truth table for a 1 : 2 digital DEMUX. The Boolean algebraic expression for a two-output DEMUX switch is  $\text{In}\#c(\text{Out}_1, \text{Out}_2)$ , the # symbol denoting a demultiplexer function. This expression says that, if  $c = 0$ , then the first argument ( $\text{Out}_1$  in this case) equals In and the second argument ( $\text{Out}_2$ ) is disabled; conversely, if  $c = 1$ , then  $\text{Out}_2 = \text{In}$  and  $\text{Out}_1$  is disabled. The variable preceding # is the input variable, and the symbol following # is the control data variable. The variables in brackets are the output variables of the two output demultiplexer, which possesses one input (In), one control input ( $c$ ) and two outputs ( $\text{Out}_1$  and  $\text{Out}_2$ ). A demultiplexer can have more than one output. The corresponding symbols and equivalent logic circuits are shown in Fig. 2b and c, respectively.

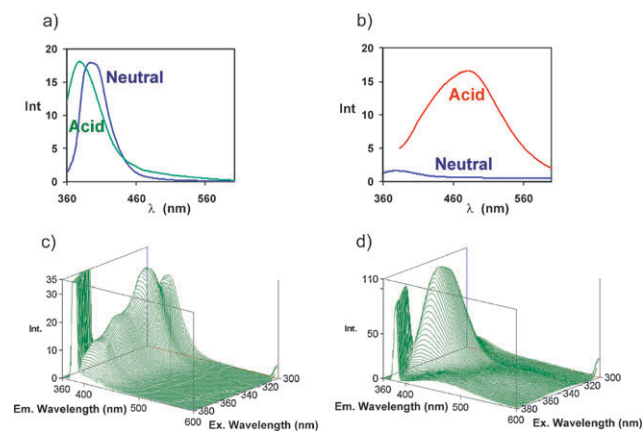


**Fig. 1** Chemical structure and proton equilibrium of compound **1**. The qualitative energy level distribution of ground and excited states that can be reached by the free and protonated forms of **1**, and the fluorescence emissions they produce on excitation at 330 nm in a neutral solution [ $\text{LE}(\text{H}^+)_{\text{em}}$ ], and on excitation at wavelengths below 330 nm [ $\text{LE}(\text{H}^+)_{\text{em}}$ ] and above 360 nm ( $\text{CT}_{\text{em}}$ ), on a acid solution containing TFA are also shown.



**Fig. 2** 1 : 2 digital demultiplexer: (a) truth table; (b) symbol; (c) equivalent circuit.

A synthetic procedure for **1** has been reported.<sup>14</sup> Two aspects of its chemical properties as regards to the interaction with a proton as input warrant careful analysis, namely: the tunable ability of the isoquinoline *N*-oxide moiety as an electron acceptor and the resulting fluorescence profile. In its free, unprotonated form, the isoquinoline *N*-oxide is a poor electron acceptor, even in its electronic singlet excited state, so it cannot be deactivated by electron transfer from the bridged electron donor. Consequently, only the corresponding fluorescent locally excited (LE) emission at 394 nm ( $\phi_{\text{fluor}} = 2 \times 10^{-3}$ ) can be obtained (Fig. 3a) by excitation at any absorbing wavelength. However, the oxygen in the isoquinoline *N*-oxide can bind to the proton in a reversible manner and enhance its electron acceptor ability. This allows an electron to be photochemically promoted from the bridged electron donor moiety to the excited state of the protonated isoquinoline *N*-oxide. Interestingly, two new excited states are possible for **1-H<sup>+</sup>**; one is the first singlet excited state of the protonated isoquinoline

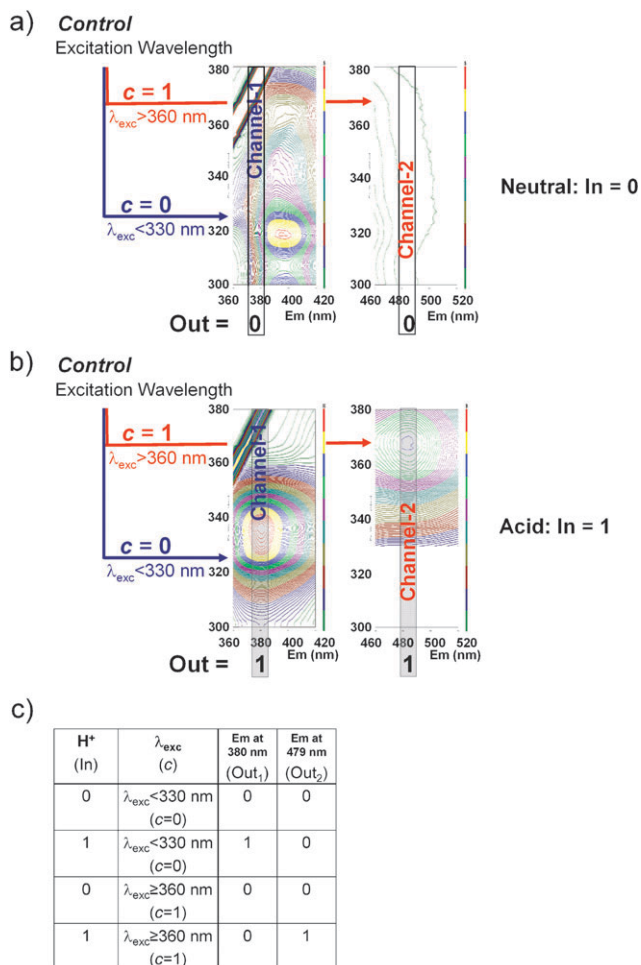


**Fig. 3** Fluorescence emission spectra for compound **1** in dichloromethane. (a) Fluorescence emission obtained on excitation at 330 nm in a neutral solution (LE, blue) and following addition of TFA (LE<sub>H<sup>+</sup></sub>, green); (b) Fluorescence emission obtained on excitation at 360 nm following addition of TFA (CT<sub>H<sup>+</sup></sub>, red): no emission was observed on excitation at the same wavelength in neutral solutions; (c) 3D fluorescence spectra for **1** in neutral dichloromethane; and (d) 3D fluorescence spectra for **1** in a dichloromethane solution containing 0.1 M TFA.

line *N*-oxide, which corresponds to the blue-shifted locally excited (LE<sub>H<sup>+</sup></sub>) fluorescence emission at 380 nm ( $\phi_{\text{fluor}} = 8 \times 10^{-3}$ ) of this protonated form and can be reached by excitation at wavelengths below 330 nm (Fig. 3a). This protonated form of compound **1** (**1-H<sup>+</sup>**) becomes a dual-fluorescence channel molecule that, by careful selection of the excitation wavelength, can produce a second, independent fluorescent emission channel. By selective excitation at wavelengths above 360 nm, the electron transfer from the ground state electron donor moiety to the excited state of the protonated isoquinoline *N*-oxide as enhanced acceptor leads to a charged transfer (CT) state that is also fluorescent ( $\lambda_{\text{em}} = 479$  nm;  $\phi_{\text{fluor}} = 2 \times 10^{-2}$ ; Fig. 3b). This allows two emissive fluorescent channels for **1-H<sup>+</sup>** to be operated by carefully selecting the excitation wavelength. It should be noted that the two fluorescent channels (LE<sub>H<sup>+</sup></sub> and CT) can be operated in an independent, no annihilating manner by taking the proton as a single input.

That the emissive behavior of a dichloromethane solution of **1** containing 0.1 M TFA is dependent on the particular excitation wavelength is clearly apparent from the three-dimensional fluorescence emissions of Fig. 3c and d. Thus, the LE emission of the protonated isoquinoline *N*-oxide is blue-shifted to 380 nm at  $\lambda_{\text{exc}} = 330$  nm and is completely displaced by a new CT band beyond 400 nm at  $\lambda_{\text{exc}} > 360$  nm. Clearly, the emissive contour of protonated **1-H<sup>+</sup>** in dichloromethane solutions is very strongly dependent on the excitation wavelength used. At short wavelengths ( $\lambda_{\text{exc}} < 330$  nm), only the LE emission of the protonated isoquinoline *N*-oxide, which is blue-shifted with respect to the neutral chromophore is observed at 380 nm. However, the presence of a new, red-shifted emission band above 400 nm when long-wavelength light is used reveals that an emissive CT state has been reached. The detectability of the CT fluorescence is further increased by its significant Stokes shift, which tends to displace it to a region not overlapped by the residual LE emission from the acceptor. One common feature of dual-channel fluorescent chemosensors is that substrate binding enhances one emission channel at the expense of the other. Our results constitute an exception to this generalization as the combination of two signaling mechanisms (*N*-oxide oxygen binding to a proton inducing electron transfer, and selection of the excitation wavelength) allows two fluorescent emission bands to be obtained. Compound **1** exhibits both LE<sub>H<sup>+</sup></sub> emission of the protonated isoquinoline *N*-oxide and an independent emission band at long wavelengths. In logic terms, the output can be high when either the proton is bound to the *N*-oxide function and careful selection of the excitation wavelength results in the independent occurrence of both emitting channels. One especially significant feature is the apparent absence of interactions between them.

The performance of compound **1** as a molecular digital demultiplexer was assessed by using a dichloromethane solution *ca.*  $10^{-5}$  M and measuring the fluorescence emission intensities at the two output destinations (380 and 479 nm) for the proton input. By using various combinations of protons and excitation light, compound **1** can be made to selectively reach a given excited state and, because all its excited states are fluorescent, the molecule can communicate a selective response for these combinations.



**Fig. 4** Interpretation of compound **1** as a 1 : 2 demultiplexer. Contour view of the three-dimensional fluorescence emission recorded in: (a) dichloromethane and (b) a dichloromethane solution containing 0.1 M TFA. The input data is forwarded to one of the two outputs (observers working at 380 and 479 nm, respectively) depending on the values of the selection control,  $c$  ( $\lambda_{\text{exc}} < 330$  nm,  $c = 0$ ;  $\lambda_{\text{exc}} \geq 330$  nm,  $c = 1$ ). (c) The truth table derived from the Boolean interpretation of the experimental data shown in (a) and (b) is consistent with that of a 1 : 2 DEMUX.

Only LE emission (channel-1) operated when control  $c$  was applied in the “off” mode ( $c = 0$ ;  $\lambda_{\text{exc}} < 330$  nm). The corresponding fluorescent emission of  $\text{LE}_{\text{H}^+}$  at 380 nm was thus observed as a consequence of proton interaction. Because the CT state (channel-2) cannot operate at  $c = 0$ , no signal was detected at 479 nm (Out<sub>2</sub>), so the output remained 0 (Fig. 4a).

For an observer (or receptor) working at 380 nm (Out<sub>1</sub>), the signal may be “on” (1) only when the arriving proton coordinates the oxygen of the isoquinoline *N*-oxide and  $c$ , in the “off” state (0;  $\lambda_{\text{exc}} < 330$  nm), drives the signal via this fluorescent channel (channel-1). However, only when  $c$ , in the “on” state (1;  $\lambda_{\text{exc}} > 360$  nm), drives the signal via channel-2 can the signal reach an observer (or receptor) working at 479 nm (Out<sub>2</sub>) (Fig. 4b).

Compound **1** meets the requirements of a 1 : 2 DEMUX since the input (proton) can be photonically addressed to either output-1 or output-2 depending on the specific setting of control  $c$  (see the table in Fig. 4c). The photophysical processes that integrate compound **1** allow it to operate via deactivation of electronically excited states or electron transfer between excited states. Since the chemical properties logically analyzed for **1** comprise no (photo)chemical reactions, problems relating to reaction rates, irradiation times and process yields (the possibility of reaching stationary distributions), which can restrict practical applications, are avoided. Consequently, molecules capable of reaching multiple nonannihilating luminescent excited states can provide promising, useful approaches to the development of molecules for optical computing.

This work was supported by Spain’s DGI (Project CTQ04-565 and CTQ07-60190).

Dedicated to Dr Jean-Pierre Desvergne in honour to his contribution to organic photochemistry.

## Notes and references

- (a) G. J. Brown, A. P. de Silva and S. Pagliari, *Chem. Commun.*, 2002, **12**, 2461; (b) V. Balzani, A. Credi and M. Venturi, *Chem-PhysChem*, 2003, **3**, 49; (c) A. P. de Silva, S. Uchiyama, T. P. Vance and B. Wannalser, *Coord. Chem. Rev.*, 2007, **251**, 1623.
- (a) S. Uchiyama, G. D. McClean, K. Iwai and A. P. de Silva, *J. Am. Chem. Soc.*, 2005, **127**, 8920; (b) D.-H. Qu, Q.-C. Wang and H. Tian, *Angew. Chem., Int. Ed.*, 2005, **44**, 5296; (c) A. P. de Silva, *Nat. Mater.*, 2005, **4**, 15.
- A. P. de Silva and S. Uchiyama, *Nat. Nanotechnol.*, 2007, **2**, 399.
- (a) A. P. de Silva, *Angew. Chem., Int. Ed.*, 2007, **46**, 2; (b) A. Credi, *Angew. Chem., Int. Ed.*, 2007, **46**, 5472.
- (a) X. Gou, D. Zhang and D. Zhu, *Adv. Mater.*, 2004, **16**, 125; (b) D. Margulies, C. E. Felder, G. Meleman and A. Shanzer, *J. Am. Chem. Soc.*, 2007, **129**, 347.
- (a) M. Han, X. Gao, J. Z. Su and S. Nie, *Nat. Biotechnol.*, 2001, **19**, 631; (b) R. Wilson, A. R. Cossins and D. G. Spiller, *Angew. Chem., Int. Ed.*, 2007, **45**, 6104; (c) C. Wu, J. Zheng, C. Huang, J. Lai, S. Li, C. Chen and Y. Zhao, *Angew. Chem., Int. Ed.*, 2007, **46**, 5393.
- (a) A. P. de Silva, N. D. McClenaghan and C. P. McCoy, in *Electron Transfer in Chemistry, Vol. 5. Molecular-Level Electronics, Imaging and Information, Energy and Environment*, ed. V. Balzani, Wiley-VCH, Weinheim, 2001; (b) A. P. de Silva, D. B. Fox, T. S. Moody and S. M. Weir, in *Molecular and Supramolecular Photochemistry. Vol. 7: Optical Sensors and Switches*, ed. V. Ramamurthy and K. S. Schanze, Marcel Dekker Inc., New York, 2001; (c) V. Balzani, M. Venturi and A. Credi, *Molecular Devices and Machines, A Journey into the Nanoworld*, Wiley-VCH, Weinheim, 2003.
- J. M. Montenegro, E. Perez-Inestrosa, D. Collado, Y. Vida and R. Suau, *Org. Lett.*, 2004, **6**, 2353.
- E. Perez-Inestrosa, J. M. Montenegro, D. Collado, R. Suau and J. Casado, *J. Phys. Chem. C*, 2007, **111**, 6904.
- J. Andreasson, S. D. Straight, S. Bandyopadhyay, R. H. Mitchell, T. A. Moore, A. L. Moore and D. Gust, *Angew. Chem., Int. Ed.*, 2007, **46**, 958.
- J. Andreasson, S. D. Straight, S. Bandyopadhyay, R. H. Mitchell, T. A. Moore, A. L. Moore and D. Gust, *J. Phys. Chem. C*, 2007, **111**, 14274.
- A. Drezet, D. Koller, A. Hohenau, A. Leitner, F. R. Aussenegg and J. R. Krenn, *Nano Lett.*, 2007, **7**, 1697.
- (a) K. Szacilowski and W. Macyk, *Solid-State Electron.*, 2006, **50**, 1649; (b) W. Macyk, G. Stocchl and K. Szacilowski, *Chem.–Eur. J.*, 2007, **13**, 5676.
- D. Collado, E. Perez-Inestrosa and R. Suau, *J. Org. Chem.*, 2003, **68**, 3574.